

ST50 MASS FLOW METER Installation and Operation Guide

Pre-Installation

Serial number Alignment

The ST50 is specified as an integral instrument with the flow element and transmitter located in the same enclosure. The flow element has a serial number etched into the side of the extension pipe as shown on figure A. The transmitter circuit card has a serial number noted on the board as shown in figure B. The flow sensor and transmitter circuit have been calibrated as a matched set and should be paired together in service unless otherwise approved by a factory technician.

Flow Direction Alignment

All sensor elements have a flow arrow indicator marked on the element assembly at the reference flat. These flow elements have been calibrated in a particular direction and are designed to be used in service with the flow arrow facing in the same direction as flow in the pipe stream.

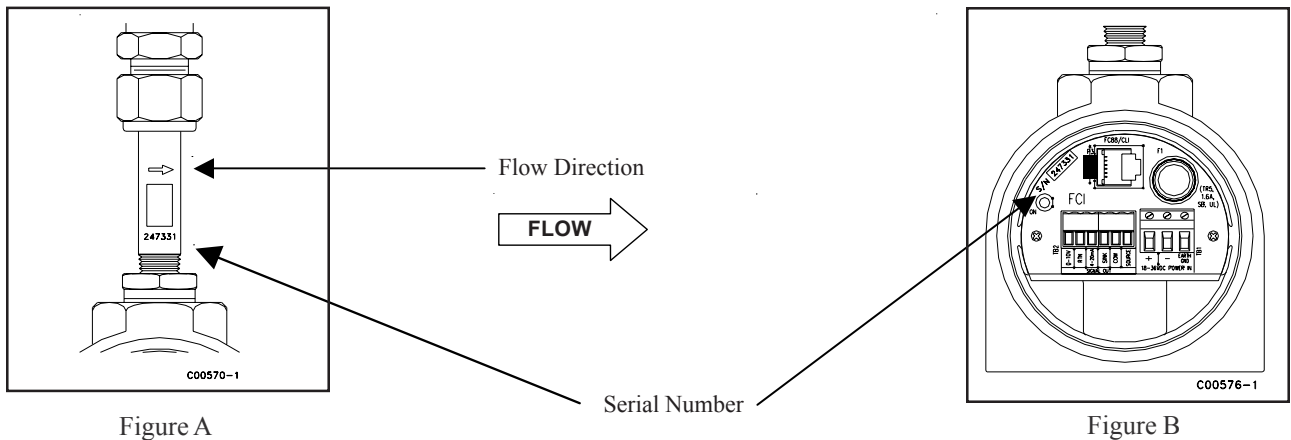

Recommended Straight Run

To optimize flow meter system performance, FCI recommends installation with a minimum of 20 pipe diameters upstream straight run and 10 pipe diameters of downstream straight run. Where straight run limitations significantly reduce the available pipe diameters, FCI utilizes Vortab flow conditioners to produce a transferable flow profile from the calibration installation to actual field installations. FCI's proprietary AVAL software is available to make flow meter installation evaluations where straight run limitations are considered. See Fig C for recommended installation.

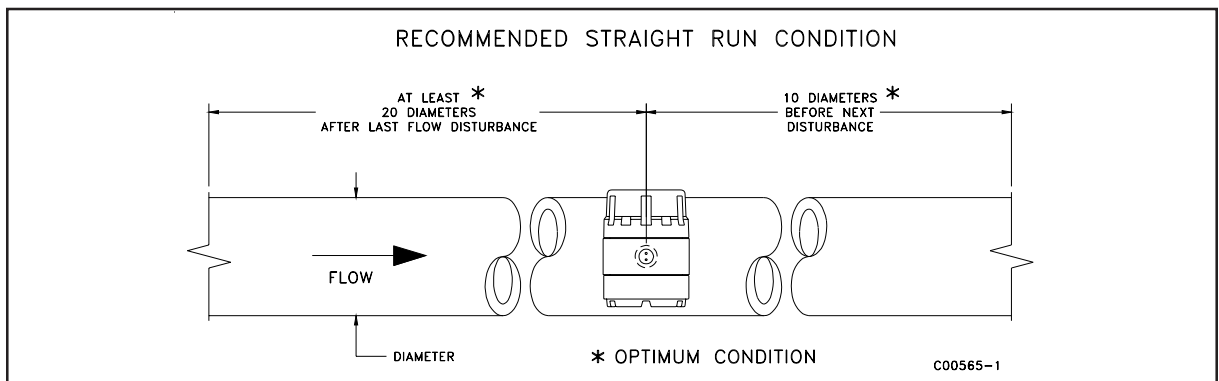

Figure C

FCI Flow Meters may be installed with less than the recommended straight run, but may have performance limitations. FCI offers Vortab flow conditioners for use in applications that have significant straight run limitations. FCI uses the AVAL application modeling software to predict meter performance in each installation. AVAL outputs are available to review prior to order placement and will indicate performance expectations both with and without Vortab Flow Conditioning.

Installing Flow Element

Insertion Depth



Warning: The element is shipped with a protective sleeve surrounding the flow element. After removing the sleeve, take care to prevent the element from sliding through the compression fitting and contacting the opposing wall with any force as it may cause damage to the element and potentially upset the calibration.

The ST50 is available with both Teflon compression fitting ferrules and metal ferrules. While the Teflon ferrule configuration can be readjusted, it is possible that over tightening may result in permanent positioning or damage to the extension pipe and will make future adjustment difficult. While Teflon provides for some adjustability, it has a lower process pressure rating and is not designed for continuous adjustments. The metal ferrule version can only be tightened down once and it becomes permanently positioned. The Ferrule type is indicated in the instrument part number displayed on the instrument tag. This can be cross referenced to the ordering information sheet.

All flow meters have been calibrated with the flow element located at the centerline of the pipe and flow stream. Couplings and threadollets come in various dimensions. Proper installation requires that the element be measured with consideration to process connection dimensions and pipe centerline. See Figure D below. FCI recommends that the element be first installed in the line with the compression fitting lightly tightened around the extension, then slowly move the pipe extension forward until the element is at centerline as shown.



Warning: On top mount installations, particularly, take care to prevent the element from sliding through the compression fitting and contacting the opposing wall with any force as it may cause damage to the element and potentially upset the calibration.

FLOW ELEMENT INSTALLATION & “U” LENGTH ADJUSTMENT

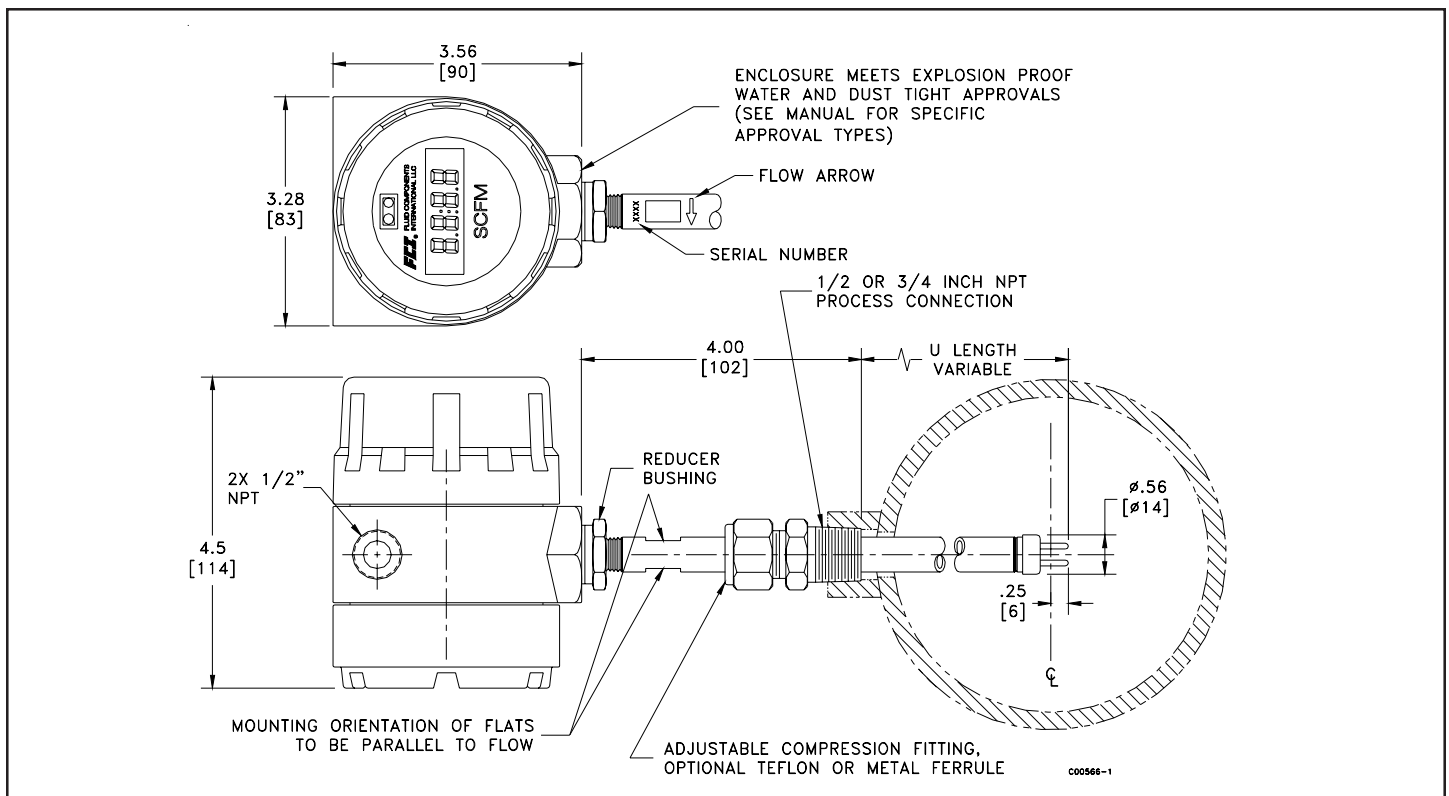

Figure D

Note: For proper performance, element shall be installed so that tip of probe is .25 inches [6mm] past pipe centerline. Instrument is specifically calibrated for centerline referenced installation. Critical for line sizes 4" [25mm] and smaller.

To assist in final installation, FCI suggests making a readable mark on the extension pipe to indicate the final desired compression fitting position on the extension pipe that will place the element at the centerline reference once the system is tightened down into place. With the compression fitting lightly tightened, hold the element assembly along the outside of the installation, or directly above, to visually verify the compression fitting location will ensure centerline installation. To calculate the actual "U" length dimension, take the inside diameter of the pipe or duct divide by 2, then add 0.25", then add for the pipe wall thickness and the process fitting offset that allows the compression fitting to securely seat in the process port. See Figure D above.

Align the flat parallel to flow and adjust the instrument depth. Upon determination of the final compression fitting location on the extension pipe, apply the proper thread sealant to the NPT threads, firmly tighten the compression fitting into the mating process connection. Torque varies per application. Tighten the compression nut to the torque indicated with the corresponding ferrule material. Manufacturer recommends 1-1/4 turns from hand tight baseline.

Ferrule	Torque
Teflon	65 in – lbs
316 SST	65 ft – lbs

Instrument Wiring

Before the instrument is opened to connect power and signal, FCI recommends that the following ESD precautions be observed:

Use a wrist band or heel strap with a 1 megaohm resistor connected to ground. If the instrument is in the shop setting, there should be a static conductive mat on the work table or floor with a 1 megaohm resistor connected to ground. Connect the instrument to ground. Apply antistatic agents such as Static free made by Chemtronics (or equivalent) to hand tools to be used on the instrument. Keep high static producing items away from the instrument.

The above precautions are minimum requirements. The complete use of ESD precautions can be found in the U.S. Dept of defense handbook 263.



Warning: Only Qualified personnel are to wire or test this instrument. The operator assumes all responsibility for safe practices while wiring and trouble shooting.

FCI recommends installing an input power disconnect switch and fuse near the instrument to interrupt power during installation and maintenance. Operator must have power disconnected before wiring.

Safety instructions for the use of the ST50 series (18 to 36VDC version only) in Hazardous Areas. Approval, KEMA 06ATEX0207 X for Category 3 GD protection EEx nA T6 T65°. Special conditions for safe use:

- 1) Provision shall be made to prevent the rated Voltage from being exceeded by transient disturbances of more than 40%.
- 2) For applications in explosive atmospheres caused by air/dust mixtures, cables and conduit entries shall be provided a degree of protection of at least IP65 according to EN60529.

Input Power

The ST50 is available with both VDC and VAC input power configurations. Customers selecting VDC input power will have a VDC input board only. Similarly, the VAC power board is supplied only with VAC powered units. In addition, both boards are marked for either AC or DC power. Only connect the power specified on the wiring module as shown on Figures E and F respectively. Both VAC and VDC inputs require a Gnd wire to be connected. Input power terminal blocks are rated for 14-26 AWG.

To wire the instrument, ensure that the power is off. Pull the power and signal output wires through the port, using care not to damage wires. FCI recommends using crimp lugs on the output wires to ensure proper connection with the terminal strip. Connect the output wires as shown on figures E and F. Note that for 4-20mA and 0-10V outputs being used simultaneously, a single return lead is used. The 4-20mA or the 0-10V outputs may be used individually or combined.

Analog Output ~ Factory default setup: 4-20mA Flow, 0-10V Temperature

4-20mA: The instrument is provided with a standard set up, of a single 4-20mA, configured for flow (500 ohm max load). Terminal blocks rated for 14-28 AWG.

0-10V: To additionally activate the 0-10V for either flow or temperature, the operator must access the software using either an FC88, computer or compatible PDA device. Instructions for activating the temperature output, can be found in the software segment that follows. Terminal blocks rated for 14-28 AWG.

Pulse Output Activation

The ST50 can be configured with an optionally ordered pulse output feature. When ordered, the software is set up and verified in advance in either a sink or source mode. The mode can be changed in the field. Wiring either sink or source mode is shown in Figures E and F below. Though only one configuration is shown with the VAC and VDC power supplies, the source or sink can be utilized with either power input.

Sink Mode: 40 VDC Max, 150 mA max. Customer supplied power source

Source Mode: 15 VDC output, 50 mA max

VDC Power Connection

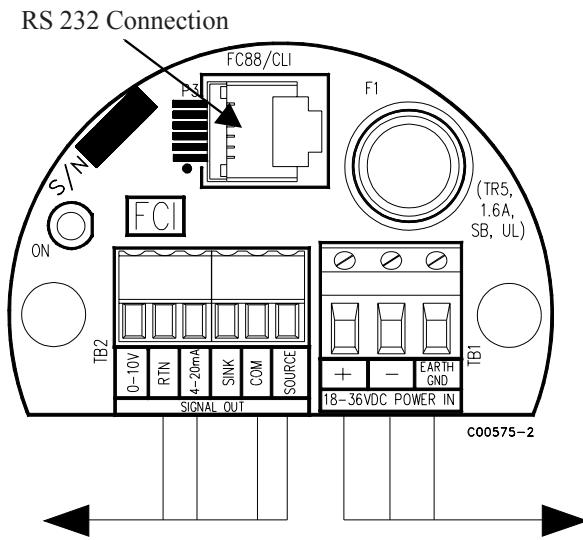

Figure E

VDC Power
 As Shown:
 18-36VDC power connected with gnd
 4-20mA connected for flow
 Open collector in source mode
Note: In source mode, 15VDC Output max, 50mA max.

VAC Power Connection

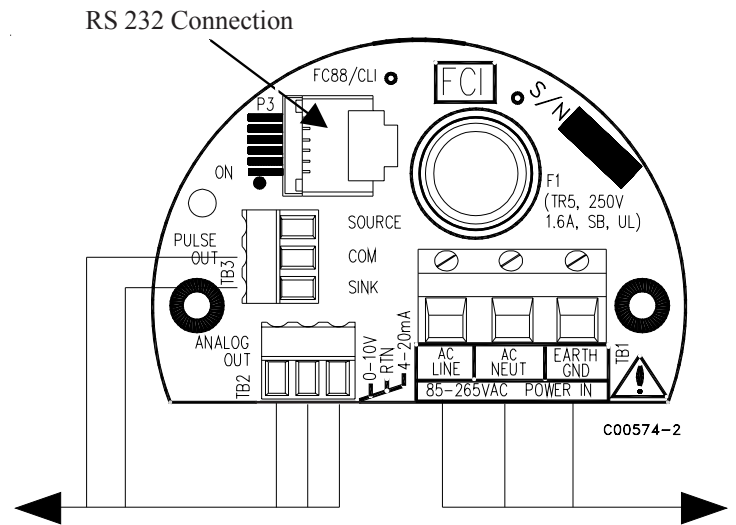

Figure F

VAC Power
 As Shown:
 85-265 VAC power connected with gnd
 4-20mA connected for flow and 0-10V connected for Temp
 Open collector in sink mode
Note: In sink mode, 40VDC max, 150mA max customer supplied power source.

Setup Interface

All parameters on this meter are set through the RS232 interface connection (P3 plug) or PDA IR interface. A jumper selection determines which communication mode is active. The factory default communication mode is set for the RS232 interface. This setting allows the instrument to be setup with either a FC88 hand held communicator or a computer. The FC88 is powered through the meter and comes with the serial interface cable. If a computer interface is used, an adapter (RJ to 9 pin Computer Serial Port) is required and may be obtained from FCI: Part No. 014108-02.

Using Windows Terminal (usually located in Accessories) execute the program by double-clicking on the Terminal Icon.

1. Go to *Settings*.
2. Click on *Communication*.
3. Set for COM1 or COM2, 9600 Baud, 8 Bit, and No Parity. Press OK
4. Press the *ENTER* key to see the *Input Mode?* prompt.
5. Enter any of the meters single letter commands to execute a function (reference complete function menu in Appendix A).

If the PDA IR interface is used for communication, then jumper JP5 needs to be moved to the alternate position, see Figure G and H. See PDA IR Communication Interface section for more details.

An additional command line interface (CLI) is available through the RS232 port. This interface is accessed with the “Y” command using a computer or FC88. The command line password is “357”. See Appendix A - Table 6 for command line details.

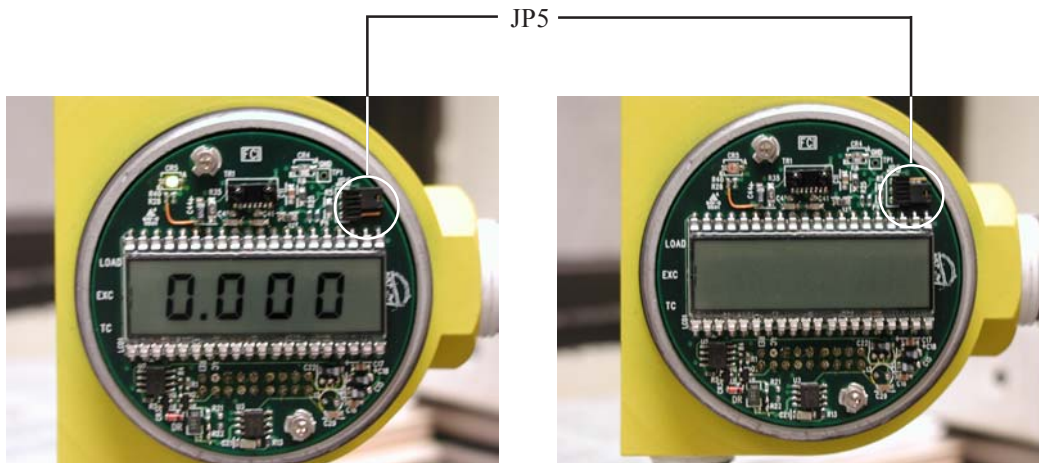
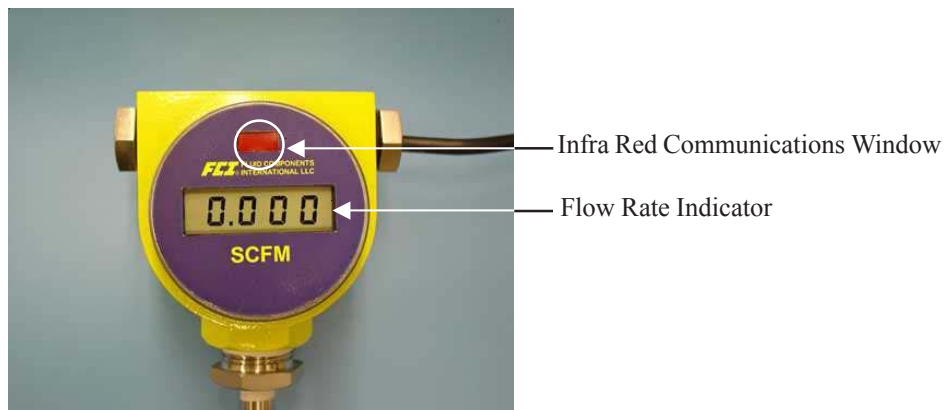

Figure G
JP5 factory set for RS232 interface

Figure H
JP5 set for PDA IR interface



Display and Transmitter Access

Start up and Commissioning

1. Verify all Input power and output signal wiring is correct and ready for initial power start up.
2. Apply power to instrument. The instrument will initialize in the Normal Operation Mode. All outputs will be active and instruments with the display option will indicate flow with the factory set flow unit. Allow 10 minutes for the instrument to warm up and come to the thermal equilibrium.

The following FC88 commands are typical commands that are used during start up and commissioning:

Command	Name	Description
T	Normal Operation Mode	All outputs are active
Z	Flow Unit Set-Up	Select Flow Units(4 English, 4 Metric)Pipe Dimensions
W	Totalizer	Enable/Disable
V	Output Configuration	Select one of 4 Configurations: Pulse and/or AlarmPulse factor and/or setpoint
F	K-Factor (default=1)	Flow factor
N	Warm Re-set	Re-initialize C/B
S	Totalizer Menu	Enables W menu (Option)

If the instrument is installed, and the process flow is zero, the instrument will now indicate 0.000. The engineering unit of flow is indicated on the instrument bezel. If the flow units are modified, additional units indicators are provided with adhesive backing.

Flow Unit Modification

Example: SCFM Flow Units and 3 inch Sch 40 round pipe size set up:

Enter	Display	Description
Enter	menu: >	From Normal Operation Mode
Z	E for English M for Metric >	Flow Unit Set-Up menu
E	0=SFPS, 1=SCFM, 2=SCFH, 3=LB/H, 4=GPM #	English units
1	R round duct or S rectangular>	Select Standard Ft ₃ /Min (SCFM)
R	Dia.: 4.0260000 Change? (Y/N)>	Select Round Duct
Y	Enter value: #	
3.068	area: 7.3926572 CMinflow: 0.0000000 Change? (Y/N)>	3 inch Sch. 40 pipe I.D.
N	Maximum flow: 462.04 Enter to continue	
Y	Cmaxflow: 462.04 Change? (Y/N)>	
Y	#	
462.04	CMintemp (F): -40.00000 Change? (Y/N)>	
N	CMaxtemp (F): 250.00000 Change? (Y/N)>	
N	Percent of Range is: OFF Change to ON?>	
N	LCD Mult Factor x1 Change? (Y/N)>	
N	100.0 SCFM	Instrument will end up in Normal Operation Mode

RS232 / FC88

Menu Control and Organization

Most entries require at least two key strokes; a Capital letter and the [ENTER] key, or one or more numbers and the [ENTER] key. All user entries begin at the input mode prompt ">", except when the instrument is in the Main Function Mode (just press the desired function letter and [ENTER] to make an entry).

Backspaces are made using the backspace [BKSP] key. Some entries are case sensitive between numbers and letters. Be sure the SHIFT key is pressed to indicate the correct case. A square after the prompt caret indicates the FC88 is in lower case. A slightly raised rectangle in the same spot indicates the FC88 is in the upper case.

It is recommended that the FC88 be plugged into the instrument before power is applied. If the FC88 is plugged in while the instrument power is on and the FC88 does not respond, press [ENTER], if there is still no response Press [N] or cycle the power.

Note: The Zero and Span may be changed from the original calibration, provided the new values are within the original calibrated range. i.e. If the original calibration was 1 to 100 SCFM (4-20mA), the new zero (4mA) must be equal to or greater than 1 SCFM, the new span (20mA) must be equal to or less than 100 SCFM.

Some entries require a Factory pass code. If this occurs contact FCI Field Service to continue programming the instrument. The instrument will prompt the user when this is necessary. Do not change any parameters that require this code unless there is an absolute understanding of the instrument's operation. The user can not exit some routines unless all entries are completed or the power is recycled.

The top level of the menu is shown in Appendix A - Table 5. Enter the large letter in the tables below to activate a command. The user may exit a command at any time entering "Q" [ENTER] in the menus: D, K, V, W, or Z.

C Calibration Information	Display only: A/D, Delta-R, Ref-R data values
D Diagnostics	Display only: List of unit parameters.
K Factory Calibration Settings	Display only: Cal. parameters, i.e. linearization and temperature compensation coefficients.
R Factory Reset	Replaces user data with factory calibration data

Table 1. Diagnostics and Factory Settings

Units		
<i>Select</i>	E=English	M=Metric
<i>Select</i>	0= SFPS	5 = SMPS
<i>or</i>	1 = SCFM	6 = NCMH
<i>or</i>	2 = SCFH	7 = NCMH
<i>or</i>	3 = LBS/H	8 = KG/H
<i>or</i>	4 = GPM	9 = LPM
For Volumetric or Mass Flow		
<i>Select</i>	R = Round pipe or duct	
<i>or</i>	S = Square duct	
<i>Set</i>	Diameter or Wide X High (in inches or mm)	
<i>Set</i>	CMaxflow = Maximum flow rate (span)	
<i>Set</i>	CMinflow = Minimum flow rate (zero)	

Note: Changing units requires rescaling the unit (set new zero and span).

Table 2. "Z" Flow Units Set-Up and Scaling

<u>Analog out</u>					
	<i>Select</i>	<u>1</u>	<u>2</u>	<u>3</u>	<u>4</u>
4-20mA out		Flow	Flow	Temp	Temp
0-10V out		Temp	Flow	Flow	Temp
<u>Pulse out</u>					
	<i>Select</i>	<u>1</u>	<u>2</u>	<u>3</u>	<u>4</u>
Source out		Pulse	Pulse	Alarm0	Alarm0
	<i>Set</i>	Factor	Factor	Set pt.0	Set pt.0
	<i>Set</i>	Period	Period	State0	State0
	<i>Set</i>	State0	State0		
Sink		Pulse	Alarm1	Pulse	Alarm1
	<i>Set</i>		Set pt.1	Factor	Set pt.1
	<i>Set</i>	State1	State1	Period	State1
				State1	

Table 3. "V" Output Configuration Set-Up

“V” Menu Output Configuration Set Up

NOTE: The display comes up to the last setting saved and stays for 2 seconds. If **N** or **[ENTER]** is entered, the menu proceeds to the Pulse out. If **Y** is entered, the display moves to the selection options and/or asks for confirmation. If you miss the option, select **[Enter]** repeatedly to loop around.

Analog out

Output Mode
Selected

4-20mA: Flow
0-10V: Temp

Change? (Y/N)>

4-20mA: Flow
0-10V: Temp
 Enter 1 to make
 the selection__
4-20mA: Flow
0-10V: Flow
 Enter 2 to make
 the selection__
4-20mA: Temp
0-10V: Flow
 Enter 3 to make
 the selection__
4-20mA: Temp
0-10V: Temp
 Enter 4 to make
 the selection__

Pulse out

Pulse Out
Selected

Source: Pulse
Sink: Pulse

Change? (Y/N)>

Source: Pulse
Sink: Pulse
 Enter 1 to make
 the selection #__
Source: Pulse
Sink: Alarm1
 Enter 2 to make
 the selection #__
Source: Alarm0
Sink: Pulse
 Enter 3 to make
 the selection #__
Source: Alarm0
Sink: Alarm1
 Enter 4 to make
 the selection #__

PFactor: 1.000
Change? (Y/N)>

if yes
Enter new factor: ____

Sample Period: 1 second
Change? (Y/N)>

if yes
Enter new Sample Period: ____

If alarm is a selected output

Set point1: 000 Set points are in the
 same units as the flow
 or temp.

Change? (Y/N)>

if yes
Enter new set point: ____

Resume normal operation

Source state:
High to Low

Change to Low to High?>

Example: COMMAND V (Reference Table 3)

Case: 4-20mA = flow, 0-10V = Temperature, Source Out = Pulse,

Sink = Alarm

Pressing **[V]** **[ENTER]** will display

“4-20mA = Flow”

“Change? (Y/N)”

Press **[ENTER]** (no change).

“Output Mode Selected”

“ 0-10V = Temp”

followed by:

followed by

The last saved mode will display at this point. i.e.,

“Source: Pulse”

“Change? (Y/N)”

“Source: Pulse”

“Enter 1 to make the selection #.”

“Source: Pulse”

“Enter 2 to make the selection #.”

“PFactor: 1.000”

“Sink: Pulse”

Select **Y** **[Enter]**.

“Sink: Pulse”

Select **[ENTER]**.

“Sink: Alarm”

Select **2** and **[ENTER]**.

“Change? (Y/N)>”

followed by,

The display reads,

followed by,

The next display reads,

followed by,

The next prompt reads,

(this factor can be anywhere from 0.001 to 1000 - A pulse factor of 1.000 will output 1 pulse per unit of flow.)

If no change, select **N** and/or **[ENTER]** to continue.

The next prompt is, “Sample Period”

“Change? (Y/N)>”

(this value may be set from 0.5 to 5 seconds)

If no change, select **N** and/or **[ENTER]** to continue.

The next prompt is, “Source state: ” “High to Low” Change to “Low to High?>”

(this selection toggles the pulse signal normally high or normally low).

[ENTER] to read display.

“Switchpt1” “0.000000” the current set point.

“Change? (Y/N)>” enter **Y** **[ENTER]** and enter #____. Set Point Value, i.e. 50 (value is in same units as the flow and must be within the calibrated range). **[ENTER]**. The next prompt is,

“Sink state: ” “High to Low” Change to “Low to High?>”. Set the output signal to be normally “High” or normally “Low.” Pressing **[Y]** **[ENTER]** toggles the current setting. Pressing **[ENTER]** resumes normal operation.

PDA IR Communication Interface

The IR interface software is an optional accessory kit and can be ordered using FCI part number 019819-01. The software is compatible with PALM OS 4.1 or greater. If the software was ordered with the instrument, a CD should be located with the instrument documentation.

The factory has verified the following 3 PDA models. All commands meet their intended purpose and function properly.

1. Palm, Tungsten E, Palm OS 5.2.1
2. Palm, Zire 71, Palm OS 5.2.1
3. ecom instruments, m 515-EX, Intrinsically-safe. Palm OS 4.1

Procedure:

1. Download the software into the target PDA. When complete, a yellow and blue FCI icon will be available.
2. Verify JP5 jumper is set in the PDA IR interface position, see Figure H.
3. Select FCI icon on PDA device.
4. The opening menu is displayed, select start.
5. Five menu groups are displayed.

Process: displays current process variables (Flow and Temperature)

ID-Unit: displays model, firmware version, serial no. ...

Set-up: allows access to the following areas

Units	K Factor
Line size	Temp/Flow min/max
Totalizer	Output Cal
LCD	Output Config

Diagnostics: A/D values

Utilities: allows access to the following areas

- Reset
- Parameter memory
- Calibration coefficients
- Factory restore
- Process and System Faults

6. After entering into specific menu areas, point the PDA IR port towards the Instrument display. Begin with the PDA device within 5 feet of the instrument display. Select the "Get All" or "Get" button to retrieve information from the instrument. If a value needs to be changed, the value must first be retrieved.

Example reading standard process variable information:

1. Verify instrument and PDA are functioning.
2. Select FCI icon on the PDA.
3. Select the start button on the opening screen.
4. Select the "Process" button.
5. Point the PDA at the instrument display, start with the PDA no further than 5 feet from the instrument.
6. Select the "Get Data" button.
7. Flow and temperature Data will begin streaming to the PDA.
8. If the IR link is interrupted, a "Command response timed out" message will be displayed.
9. Repeat the process if the link is interrupted.

Maintenance

The FCI instrument requires little maintenance. There are no moving parts or mechanical parts subject to wear in the instrument. The sensor assembly which is exposed to the process media is composed of 316 SS and Hastelloy C.

Without detailed knowledge of the environmental parameters of the application surroundings and process media, FCI cannot make specific recommendations for periodic inspection, cleaning, or testing procedures. However, some suggested general guidelines for maintenance steps are offered below. Use operating experience to establish the frequency of each type of maintenance.

Calibration

Periodically verify the calibration of the output and recalibrate if necessary. FCI recommends every 18 months at a minimum.

Electrical Connections

Periodically inspect cable connections on terminal strips and terminal blocks. Verify that terminal connections are tight and physically sound with no sign of corrosion.

Remote Enclosure

Verify that the moisture barriers and seals protecting the electronics in the local enclosure is adequate and that no moisture is entering the enclosure.

Electrical Wiring

FCI recommends occasional inspection of the system's interconnecting cable, power wiring and flow element wiring on a "common sense" basis related to the application environment. Periodically the conductors should be inspected for corrosion and the cable insulation checked for signs of deterioration.

Flow Element Connections

Verify that all seals are performing properly and that there is no leakage of the process media. Check for deterioration of the gaskets and environmental seals used.

Insertion Type Flow Element Assembly

Periodically remove the flow element for inspection based on historical evidence of debris, foreign matter, or scale build-up and appropriate plant shutdown schedules and procedures. Check for corrosion, stress cracking, and/or build-up of oxides, salts, or foreign substances. The thermowells must be free of excessive contaminants and be physically intact. Any debris or residue build-up could cause inaccurate flow indication. Clean the flow element, as necessary, with a soft brush and available solvents (compatible with Stainless Steel).

Troubleshooting

Application Verification

After verifying that the flow meter is functioning, review the application parameters as shown below to verify the calibration matches the process media.

Equipment Needed

Flow Instrument Calibration Data

Process Parameters and Limits

Check Serial Numbers

Verify that the serial number of the flow element and the flow transmitter electronics are the same. The flow element and the flow transmitter are a matched set and cannot be operated independently of each other.

Check the Instrument Installation

Verify correct mechanical and electrical installation. Verify the flow element is mounted at least 20 diameters downstream and 10 diameters upstream from any bends or interference in the process pipe or duct.

Check for Moisture

Check for moisture on the flow transmitter. Moisture may cause intermittent operation. Check for moisture on the flow element. If a component of the process media is near its saturation temperature it may condense on the flow element. Place the flow element where the process media is well above the saturation temperature of any of the process gases.

Check Application Design Requirements

Application design problems may occur with first time application instruments, although the design should also be checked on instruments that have been in operation for some time. If the application design does not match field conditions, errors occur.

1. Review the application design with plant operation personnel and plant engineers.
2. Ensure that plant equipment such as pressure and temperature instruments conform to the actual conditions.
3. Verify operating temperature, operating pressure, line size, and gas medium.

Verify Standard Versus Actual Process Conditions

The flowmeter measures the mass flow rate. The mass flow rate is the mass of the gas flowing through a pipe per time. Other flow meters, such as an orifice plate or a pitot tube, measure the volumetric flow rate. The volumetric flow rate is the volume of gas per time. If the readings displayed do not agree with another instrument, some calculations may be necessary before comparing them. To calculate the mass flow rate, the volumetric flow rate, and the pressure and temperature, the point of measurement must be known. Use the following equation to calculate the mass flow rate (Standard Volumetric Flow rate) for the other instrument:

Equation:

$$Q_s = Q_A \times \frac{P_A}{T_A} \times \frac{T_s}{P_s}$$

Where:

Q_A = Volumetric Flow Q_s = Standard Volumetric Flow

P_A = Actual Pressure T_A = Actual Temperature

P_s = Standard Pressure T_s = Standard Temperature

PSIA and °R are used for pressure and temperature units.

(Metric: Where bar(a) and °K are used for pressure and temperature.)

Example:

Q_A = 1212.7 ACFM

P_A = 19.7 PSIA

P_s = 14.7 PSIA

Q_s = 1485 SCFM

T_A = 120°F (580°R)

T_s = 70°F (530°R)

(Metric: P_s = 1.01325 bar(a))

T_s = 21.1°C (294.1K))

$$\left(\frac{1212.7 \text{ ASFM}}{1} \right) \left(\frac{19.7 \text{ PSIA}}{580^\circ \text{ R}} \right) \left(\frac{530^\circ \text{ R}}{14.7 \text{ PSIA}} \right) = 1485 \text{ SFCM}$$

Calibration Parameters Verification

The instrument uses a set of predetermined calibration parameters to process flow signals. Most of these parameters should not change. A data package located with this manual contains the “ST50 Delta R Data Sheet”. This contains the calibration parameters stored in the flow transmitter at the factory. To verify that these parameters have not changed, complete the following:

1. Identify the appropriate Delta R Data sheets by serial number of the instrument.
2. Press [D] [ENTER] to examine each of the parameters. The [ENTER] key allows scrolling one message at a time. Use Table 4 to verify parameters with the Delta R Data sheet ST50 Parameters.

S/W Version:		dR Min:		Zero DAC 1:	
Flow Factor:		dR Max:		T Span DAC 0:	
Cmin Flow:		Cal Ref:		T Zero DAC 0:	
Cmax Flow:		Tcslp:		T Span DAC 1:	
Eng Units:		Tcslp 0:		T Zero DAC 1:	
Line Size 0:		Tcslp 2:		State 0:	
Line Size 1:		Tot Menu:		Switch Pt 0:	
Cmin Temp:		Tot Flag:		State 1:	
Cmax Temp:		Totalizer:		Switch Pt 1:	
Min Flow:		Rollover Cnt:		K factor 1:	
Max Flow:		Fix Pt Flag:		K factor 2:	
Density:		Pulse Factor:		K factor 3:	
*C1 [1]:		Pulse Out:		K factor 4:	
*C1 [2]:		Hours:		I factor:	
*C1 [3]:		Sample Period:		Temp Flag:	
*C1 [4]:		Pulse Width:		Out Mode:	
*C1 [5]:		dR Slope:		Boxcar Max:	
Break Pt:		dr Off Set:		RTD-SLP-385:	
*C2 [1]:		Refr Slope:		% of Range:	
*C2 [2]:		Refr Off Set:		LCD Multiplier:	
*C2 [3]:		Span DAC 0:		User Name:	
*C2 [4]:		Zero DAC 0:		Shop Order #:	
*C2 [5]:		Span DAC 1:		Serial No.:	

Table 4. Diagnostic Test Sequence on Display

If parameters that have an asterisk (*) have changed, this may indicate a problem. Customer Service should be contacted. If the parameters have not changed, continue with the next section.

Hardware Verification

Equipment Required:

Digital Multimeter
Screw Driver

The ST50 Flowmeter is comprised of 4 basic components:

1. Sensor element.
2. Customer interface circuit board
3. Control circuit assembly circuit board module.
4. Electronics enclosure.

Step 1

Verify fuse (F1) located on the customer interface circuit board is in normal working condition.

Remove power from the instrument. Open the electronics enclosure exposing the customer interface circuit board. This circuit board is located under the shorter enclosure lid along with all of the power and input/output connections. Unscrew the clear cover on the fuse and pull the fuse out of the fuse holder. Check the fuse for continuity. If fuse reads open, replace with equivalent component (FCI part no. 019933-01), Wickmann Inc. series 374, amp code 1160, package 41.

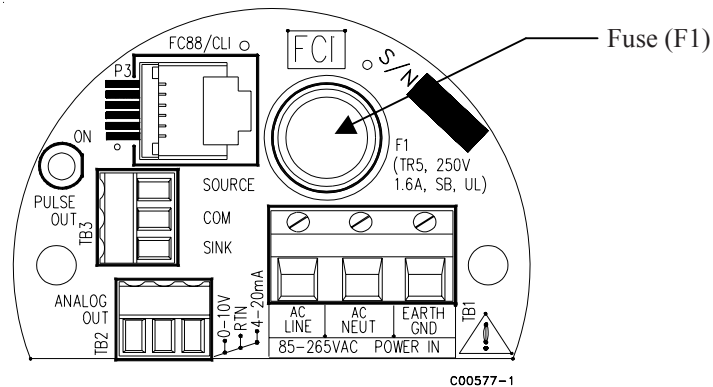

Ac power customer interface circuit board shown. Fuse (F1) on DC power customer interface circuit board located in similar position.

Step 2

Verify interconnecting cable from the customer interface board and the control circuit board assembly module are correctly seated into the appropriate header.

Remove power from the instrument. Open the electronics enclosure exposing the customer interface circuit board. This circuit board is located under the shorter enclosure lid along with all of the power and input/output connections. Remove the 2 screws securing the interface circuit board to the electronics enclosure. Carefully lift the interface face board exposing the interconnecting cable between the interface board and the control circuit assembly. Verify cable is seated firmly at both ends of the cable header.

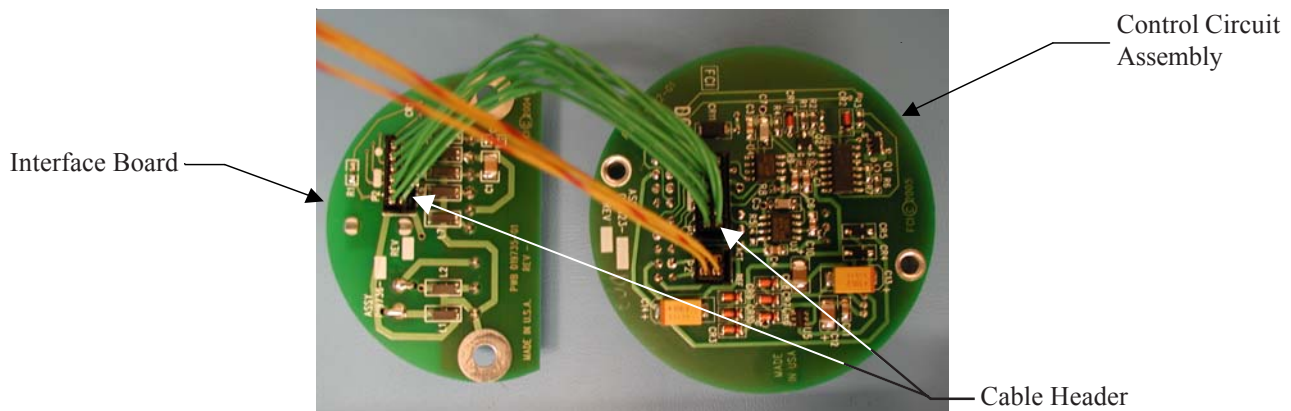

Step 3

Verify sensor element continuity and resistance.

Remove sensor element cable from the bottom of the control circuit assembly. Note that 2 of the wires have a red stripe and are located closest to the interconnecting cable header. Using an ohm meter verify that resistance between the 2 red striped wires is approximately 1100 ohms +/- 20. This resistance is temperature dependant. The resistance at 70 degrees F should be 1082 ohms. Verify the resistance between the 2 natural colored wires are approximately the same.

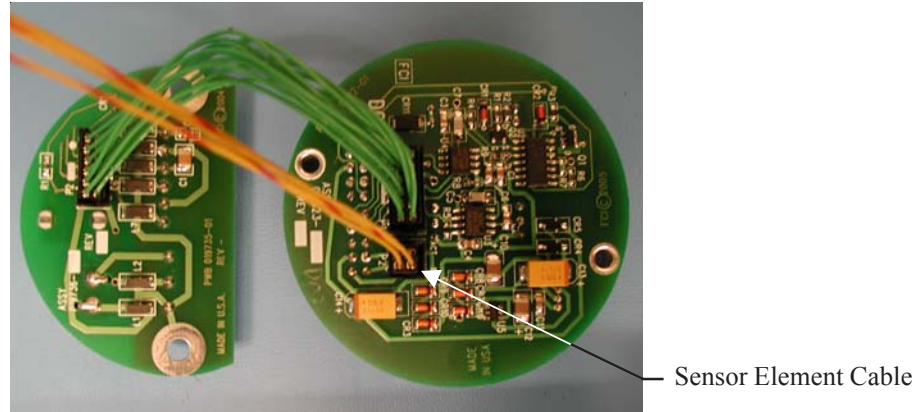

FCI provides full in-house technical support. Additional technical representation is also provided by FCI field representatives. Before contacting a field or in-house representative, please perform the troubleshooting techniques outlined in this document. If problems persist, contact the FCI Customer Service department at 1-800-854-1993 or 1-760-744-6950.

If the instrument is to be returned to FCI, please obtain a Return Authorization. The form contains a declaration of decontamination cleaning information that the instrument must comply with before it is shipped to FCI.



CE DECLARATION OF CONFORMITY Model ST50 / ST75

We, *Fluid Components International LLC*, located at 1755 La Costa Meadows Drive, San Marcos, California 92078-5115 USA, declare under our sole responsibility that the **ST50/ST75 Flowmeter Product Family**, to which this declaration relates, are in conformity with the following standards and Directives

EMC Directive 89/336/EEC of May 3, 1989 of the European Union:

Immunity specifications: EN 61000-6-2: 2001; EN 61000-4-2 1995; EN 61000-4-3: 1996; EN 61000-4-4 1995; EN 61000-4-5 1995; EN 61000-4-6 2003; EN 61000-4-8 1995; EN 61000-4-11 1994.

Emissions specification: EN 61000-6-4: 2001; EN55011 1998 Group1 Class A; CISPR 11 1997 Group 1 Class A.

Pressure Equipment Directive (PED) 97/23/EC:

The ST50 Model does not have a pressure bearing housing and is therefore not considered as pressure equipment by itself according to article 1, section 2.1. The Model ST75 is in conformity with the sound engineering practices as defined in the Pressure Equipment Directive (PED) 97/23/EC article 3, paragraph 3.

ATEX Directive 94/9/EC:

Type Examination Certificate No. KEMA 06ATEX0207 X, satisfies EN60079-15: 2003 and EN50281-1-1: 1998 + A1 requirements.

*Issued at San Marcos, California USA
28, January 2007*

A handwritten signature in black ink that reads 'Eric Wible'.

Eric Wible, Engineering Manager

Flow/Liquid Level/Temperature Instrumentation

Visit FCI on the Worldwide Web: www.fluidcomponents.com

1755 La Costa Meadows Drive, San Marcos, California 92069 USA 760-744-6950 • 800-854-1993 • 760-736-6250
European Office: Persephonestraat 3-01 5047 TTilburg – The Netherlands – Phone 31-13-5159989 • Fax 31-13-5799036

23EN000017b

INTENTIONALLY LEFT BLANK

Appendix A
LIST COMMANDS

COMMAND MNEMONIC	COMMAND FUNCTION	COMMAND DESCRIPTION
A	R	AvgDelta_r, AvgRef
B	R	Delta_r, Ref_r
C	R	Tcdelta_r, Ref_r
D	R	Diagnostics
F	R/W	Kfactors
G	R/W	Clear FlashEE, Boxcar Count, ADC to Ohms Cal
K	R/W	Cal Parameters
L	R/W	Output Cal
N	W	Warm Restart
R	W	Factory Restore
S	R/W	Totalizer Menu On/Off
T	R	Normal Mode
V	R/W	Output Config
W	R/W	Totalizer
Y	W	Command Line Interface
Z	W	Flow units, Pipe Size, and LCD Scaling

Table 5. ST50 List of Single Letter Commands

COMMAND MNEMONIC	COMMAND FUNCTION	COMMAND DESCRIPTION	DATA TYPE
BK	R/W	Break Point	Float
BM	R/W	Boxcar Filter Max	Integer
CM	R/W	Cminflow	Float
CR	R/W	Calibration Ref	Float
CX	R/W	Cmaxflow	Float
C1[1-5]	R/W	Coefficients set1	Float
C2[1-5]	R/W	Coefficients set2	Float
DI	R	Diagnostics	Null
DM	R/W	DeltaR Minimum	Float
DN	R/W	Density	Float
DR	R	Delta R	Float
DX	R/W	DeltaR Maximum	Float
DS	R/W	DeltaR Slope	Float
DF	R/W	DeltaR Offset	Float
EU	R/W	Engineering Units	Integer
FF	R/W	Flow Factor	Float
FP	R/W	Fix Point Flag	Integer
F0	R/W	Pulse Out State0	Integer
F1	R/W	Pulse Out State1	Integer
HR	R/W	Tot Dump Hours Cntr	Integer
IF	R/W	I Factor	Float

Table 6. ST50 List of CLI Commands

Table 6. ST50 List of CLI Commands, Cont.

COMMAND MNEMONIC	COMMAND FUNCTION	COMMAND DESCRIPTION	DATA TYPE
K[1-4]	R/W	K Factors	Float
L0	R/W	Line Size0	Float
L1	R/W	Line Size1	Float
MN	R/W	Minflow	Float
MX	R/W	Maxflow	Float
OM	R/W	Outmode	Integer
PF	R/W	Pulse Factor	Float
PL	R/W	Pulse Out	Integer
PS	R/W	Pulse Sample Period	Float
PW	R/W	Pulse Width	Float
P0	R/W	Switch Point0	Integer
P1	R/W	Switch Point1	Integer
RO	R/W	RollOver Cntr	Long
RR	R	Reference R	Float
RS	R/W	RefR Slope	Float
RF	R/W	RefR Offset	Float
SF	R	SFPS Flow	Float
SN	R/W	Serial Number	String (16 chars max.)
SO	R/W	Shop Order Number	String (16 chars max.)
S0	R/W	SpanDAC0 for 4-20mA	Integer
S1	R/W	SpanDAC1 for 0-10V	Integer
S2	W	Save FACTORY	N/A
TC	R	TCdeltar	Float
TD	R/W	Tcslp	Float
TF	R/W	Totalizer OFF/ON Flag	Integer
TM	R/W	Cmintemp	Float
TP	R/W	Totalizer Temperature Flag	Integer
TT	R/W	Totalizer Value	Float
TX	R/W	Cmaxtemp	Float
TZ	R	Temperature	Float
T0	R/W	Tcslp0	Float
T2	R/W	Tcslp2	Float
T3	R/W	TSpanDAC0 for 4-20mA	Integer
T4	R/W	TSpanDAC1 for 0-10V	Integer
T5	R/W	TZeroDAC0 for 4-20mA	Integer
T6	R/W	TZeroDAC1 for 0-10V	Integer
UF	R	User Flow	Float
UK	R	User FlowK	Float
UN	R/W	User Name	String (16 chars max.)
VN	R	Version Number	String (16 chars max.)
XX	R/W	Test Flow Rate (SFPS)	Float
XY	W	Delete Test Flow Rate	Float
Z0	R/W	ZeroDAC0 for 4-20mA	Integer
Z1	R/W	ZeroDAC1 for 0-10V	Integer

Command Line Password: 357

NOTE: When invoking a Write Function, there must be a space separating the Command characters and the data value. All Read and Write Functions are completed with a <CR>. To exit CLI, press <CR> following the last Command <CR>.

Examples: RBK<CR> (Read Breakpoint)
 WBK 2222<CR> (Write Breakpoint 2222)
 RC11<CR> (Read Coefficient C1,1)
 WC11 -234.567<CR> (Write Coefficient C1,1, -234.567)
 <CR> (Leave Command Line Mode)

Appendix B
DRAWINGS

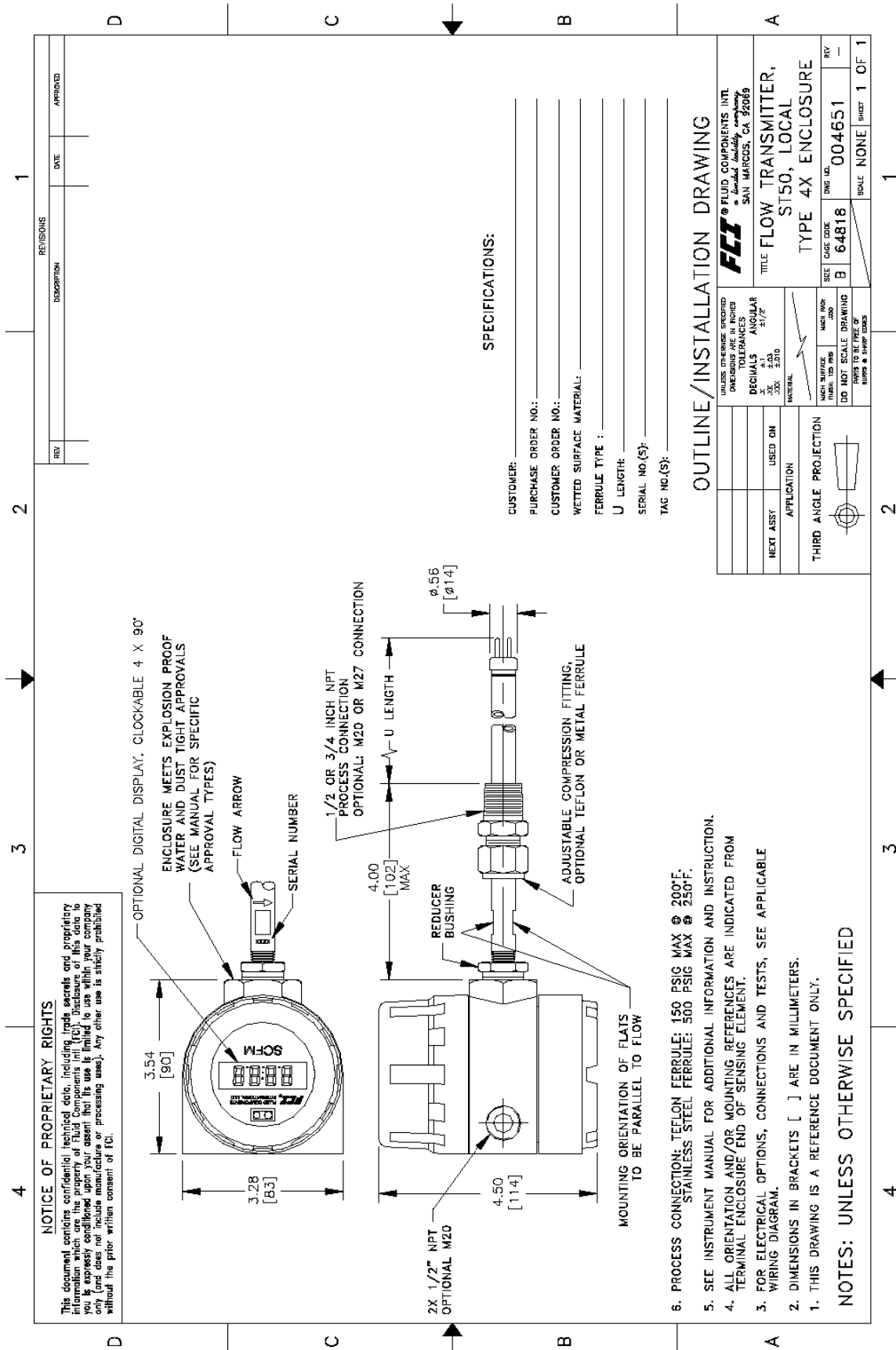

NOTICE OF PROPRIETARY RIGHTS
 This document contains confidential technical data, including trade secrets and proprietary information which are the property of Fluid Components Intl (FCI). Disclosure of this data to you is expressly conditioned upon your assent that its use is limited to use within your company only (and does not include manufacture or processing uses). Any other use is strictly prohibited without the prior written consent of FCI.

REV	DESCRIPTION	DATE	APPROVED
1			

SPECIFICATIONS:

CUSTOMER: _____
 PURCHASE ORDER NO.: _____
 CUSTOMER ORDER NO.: _____
 WETTED SURFACE MATERIAL: _____
 FERRULE TYPE : _____
 U LENGTH: _____
 SERIAL NO.(S): _____
 TAG NO.(S): _____

OUTLINE/INSTALLATION DRAWING

UNLESS OTHERWISE SPECIFIED DIMENSIONS ARE IN INCHES TOLERANCES DECIMALS ANGULAR .XX ±.03 ±1/2 .XXX ±.010 MATERIAL: _____ FINISH: TO FINISH MACH SURFACE: MACH FINISH THREADS: TO STD DO NOT SCALE DRAWING DIMS TO BE FREE OF BURRS & SHARP EDGES		SEE CASE CODE B 64818	DWG NO. 004651	REV -
TITLE FLOW TRANSMITTER, ST50, LOCAL TYPE 4X ENCLOSURE		SCALE NONE SHEET 1 OF 1		
NEXT ASSY USED ON APPLICATION	THIRD ANGLE PROJECTION			

- PROCESS CONNECTION: TEFLON FERRULE: 150 PSIG MAX @ 200°F.
 STAINLESS STEEL FERRULE: 500 PSIG MAX @ 250°F.
- SEE INSTRUMENT MANUAL FOR ADDITIONAL INFORMATION AND INSTRUCTION.
- ALL ORIENTATION AND/OR MOUNTING REFERENCES ARE INDICATED FROM TERMINAL ENCLOSURE END OF SENSING ELEMENT.
- FOR ELECTRICAL OPTIONS, CONNECTIONS AND TESTS, SEE APPLICABLE WIRING DIAGRAM.
- DIMENSIONS IN BRACKETS [] ARE IN MILLIMETERS.
- THIS DRAWING IS A REFERENCE DOCUMENT ONLY.

NOTES: UNLESS OTHERWISE SPECIFIED

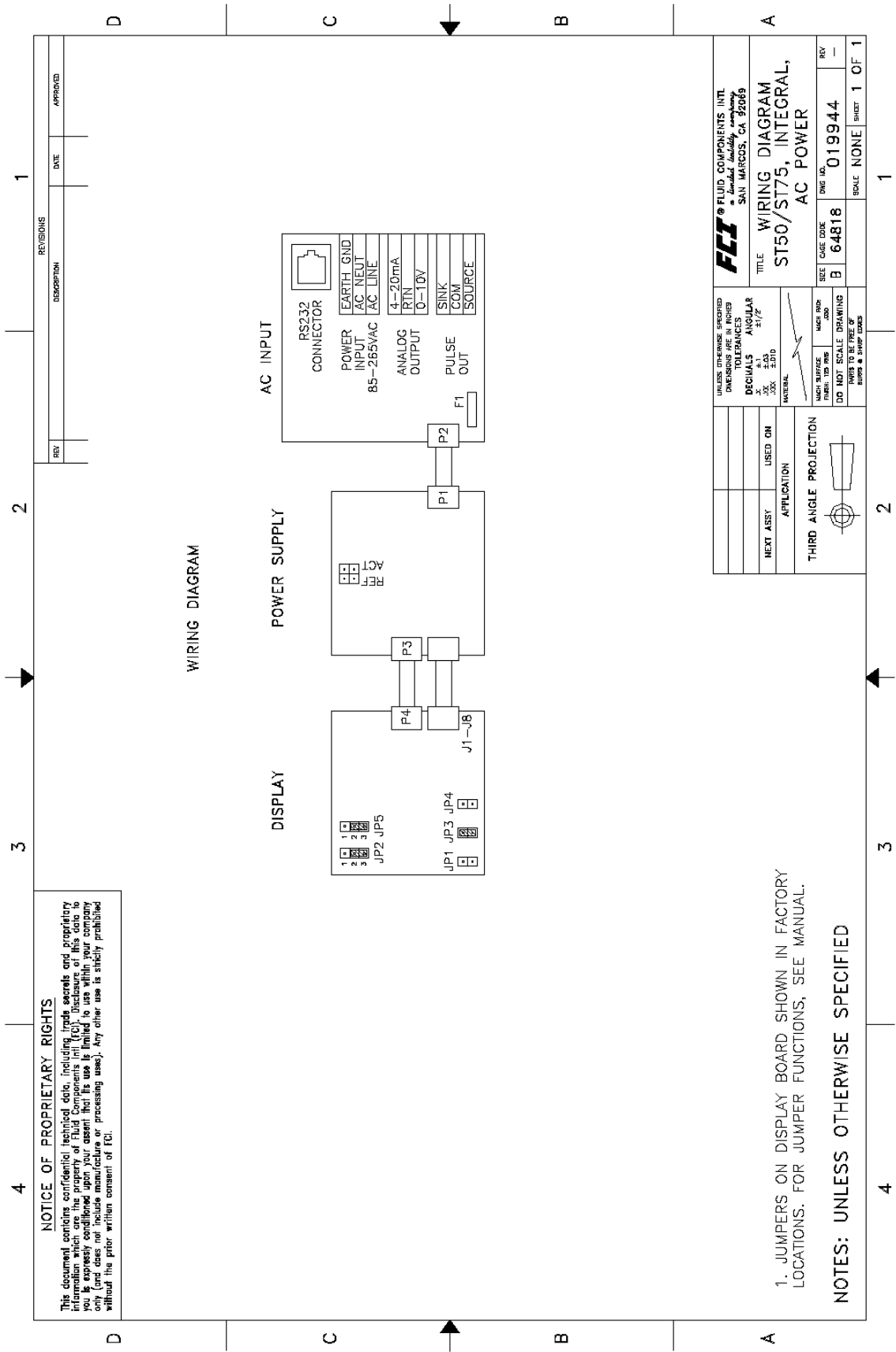

REVISIONS		
REV	DESCRIPTION	DATE

NOTICE OF PROPRIETARY RIGHTS

This document contains confidential, technical data, including trade secrets and proprietary information which are the property of Fluid Components Intl (FCI). Disclosure of this data to you is expressly conditioned upon your assent that its use is limited to use within your company only (and does not include manufacture or processing usage). Any other use is strictly prohibited without the prior written consent of FCI.

UNLESS OTHERWISE SPECIFIED DIMENSIONS ARE IN INCHES		
DECIMALS	FRACTIONS	
$\frac{1}{16}$ $\frac{1}{8}$ $\frac{3}{16}$ $\frac{1}{2}$ $\frac{5}{8}$ 1	$\frac{1}{32}$ $\frac{1}{16}$ $\frac{3}{32}$ $\frac{1}{8}$ $\frac{1}{4}$ $\frac{3}{8}$ 1	
TOLERANCES		
TITLE: WIRING DIAGRAM ST50/ST75, INTEGRAL, AC POWER DRAWING NO.: 019944 SCALE: NONE		
SIZE	CAGE CODE	REV
B	64818	1
DO NOT SCALE DRAWING		SCALE
BASED ON REV. 1		1 OF 1

1. JUMPERS ON DISPLAY BOARD SHOWN IN FACTORY LOCATIONS. FOR JUMPER FUNCTIONS, SEE MANUAL.

NOTES: UNLESS OTHERWISE SPECIFIED

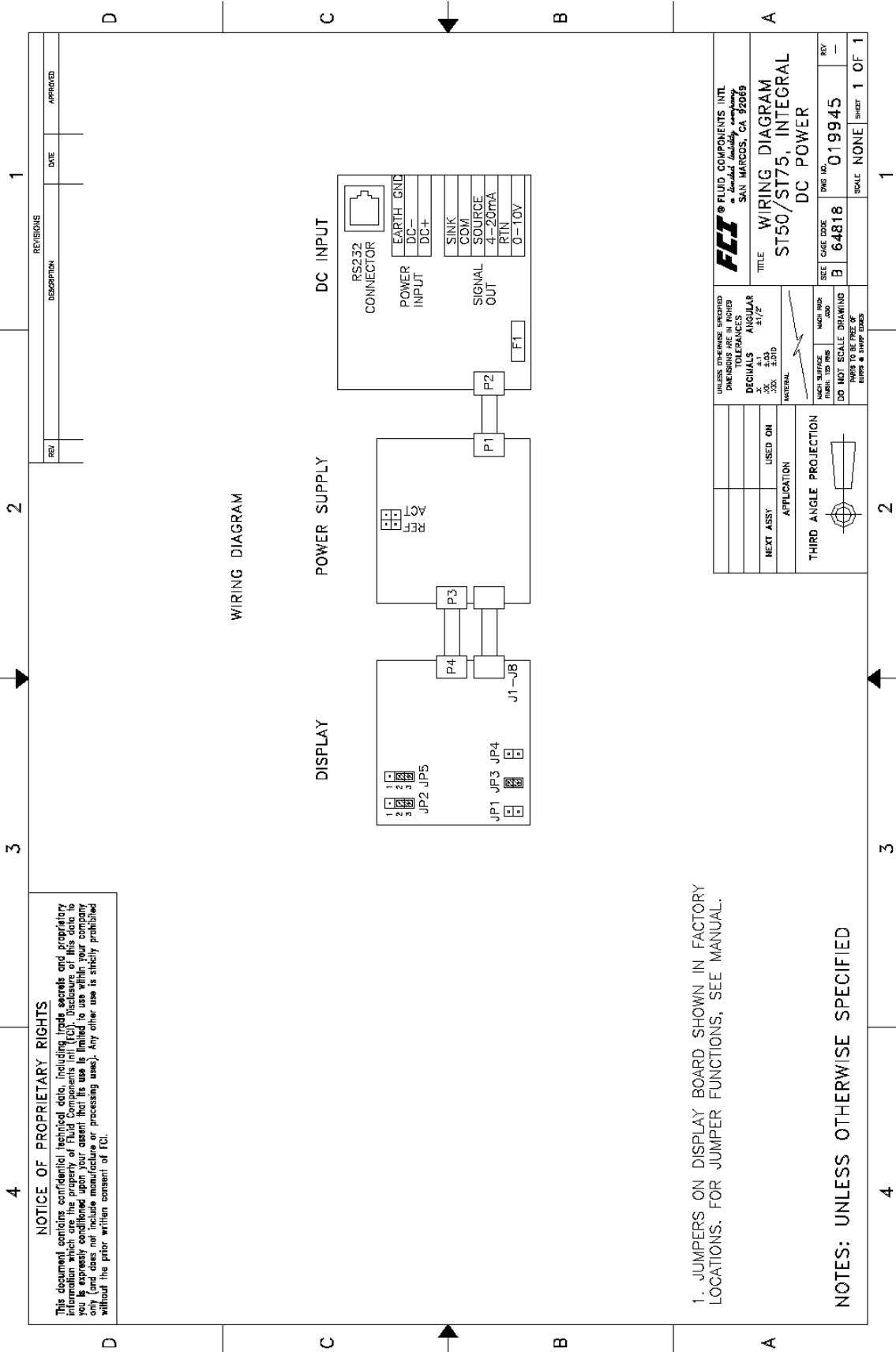

1. JUMPERS ON DISPLAY BOARD SHOWN IN FACTORY LOCATIONS. FOR JUMPER FUNCTIONS, SEE MANUAL.

NOTES: UNLESS OTHERWISE SPECIFIED

INTENTIONALLY LEFT BLANK

Notes

Instrument Warranty

Goods furnished by the Seller are to be within the limits and of the sizes published by the Seller and subject to the Seller's standard tolerances for variations. All items made by the Seller are inspected before shipment, and should any of said items prove defective due to faults in manufacture or performance under Seller approved applications, or fail to meet the written specifications accepted by the Seller, they will be replaced or repaired by Seller at no charge to Buyer provided return or notice of rejection of such material is made within a reasonable period but in no event longer than one (1) year for non-calibration defects and one (1) year for calibration defects from date of shipment to Buyer, and provided further, that an examination by Seller discloses to Seller's reasonable satisfaction that the defect is covered by this warranty and that the Buyer has not returned the equipment in a damaged condition due to Buyer's or Buyer's employees', agents', or representatives' negligence and Buyer has not tampered, modified, redesigned, misapplied, abused, or misused the goods as to cause the goods to fail. In addition, this warranty shall not cover damage caused by Buyer's exposure of the goods to corrosive or abrasive environments. Moreover, Seller shall in no event be responsible for (1) the cost or repair of any work done by Buyer on material furnished hereunder (unless specifically authorized in writing in each instance by Seller), (2) the cost or repair of any modifications added by a Distributor or a third party, (3) any consequential or incidental damages, losses, or expenses in connection with or by reason of the use of or inability to use goods purchased for any purpose, and Seller's liability shall be specifically limited to free replacement, or refund of the purchase price, at Seller's option, provided return or rejection of the goods is made consistent with this paragraph, and the Seller shall in no event be liable for transportation, installation, adjustment, loss of good will or profits, or other expenses which may arise in connection with such returned goods, or (4) the design of products or their suitability for the purpose for which they are intended or used. Should the Buyer receive defective goods as defined by this paragraph, the Buyer shall notify the Seller immediately, stating full particulars in support of his claim, and should the Seller agree to a return of the goods, the Buyer shall follow Seller's packaging and transportation directions explicitly. In no case are the goods to be returned without first obtaining a return authorization from the Seller. Any repair or replacement shall be at Seller's factory, unless otherwise directed, and shall be returned to Seller transportation prepaid by Buyer. If the returned goods shall prove defective under this clause they will be replaced or repaired by Seller at no charge to Buyer provided the return or rejection of such material is made within a reasonable period, but in no event longer than (1) year from the date of shipment of the returned goods or the unexpired terms of the original warranty period whichever is later. If the goods prove to be defective under this paragraph, the Buyer shall remove the goods immediately from the process and prepare the goods for shipment to Seller. Continued use or operation of defective goods is not warranted by Seller and damage occurring due to continued use or operation shall be for Buyer's account. Any description of the goods contained in this offer is for the sole purpose of identifying them, and any such description is not part of the basis of the bargain, and does not constitute a warranty that the goods will conform to that description. The use of any sample or model in connection with this offer is for illustrative purposes only, is not part of the basis of the bargain, and is not to be construed as a warranty that the goods will conform to the sample or model. No affirmation of that fact or promise made by the Seller, whether or not in this offer, will constitute a warranty that the goods will conform to the affirmation or promise. THIS WARRANTY IS EXPRESSLY IN LIEU OF ANY AND ALL OTHER EXPRESS OR IMPLIED WARRANTIES WITH RESPECT TO THE GOODS OR THEIR INSTALLATION, USE, OPERATION, REPLACEMENT OR REPAIR, INCLUDING ANY IMPLIED WARRANTY OF MERCHANTABILITY OR FITNESS OF PURPOSE; AND THE GOODS ARE BEING PURCHASED BY BUYER "AS IS". SELLER WILL NOT BE LIABLE BY VIRTUE OF THIS WARRANTY OR OTHERWISE FOR ANY SPECIAL, INCIDENTAL OR CONSEQUENTIAL LOSS OR DAMAGE RESULTING FROM THE USE OR LOSS OF USE OF THE GOODS.



FCI's Complete Customer Commitment. Worldwide
ISO 9001:2000 and AS9100 Certified

Notice of Proprietary Rights

This document contains confidential technical data, including trade secrets and proprietary information which is the property of Fluid Components International LLC (FCI). Disclosure of this data to you is expressly conditioned upon your assent that its use is limited to use within your company only (and does not include manufacture or processing uses). Any other use is strictly prohibited without the prior written consent of FCI.

Visit FCI on the Worldwide Web: www.fluidcomponents.com
1755 La Costa Meadows Drive, San Marcos, California 92078 USA - 760-744-6950 - 800-854-1993 - Fax 760-736-6250